

TRANSPORTADOR TUBULAR DE CADENA - TIPO VERTICAL

DIMENSIONES (PULGADAS)

TIPO	Ø	A1	A2	A3	A4	S1	S2
115	4½	33¼	31¼	31¼	10¾	31½	10⅞
140	5½	33¼	31½	35⅞	12⅞	31½	11⅞
160	6⅞	39⅞	39	37¼	12½	48	12⅞
200	8⅞	40⅞	39⅞	40⅞	13¾	48	14½
270	10¾	51⅞	64½	61½	19	60	16½

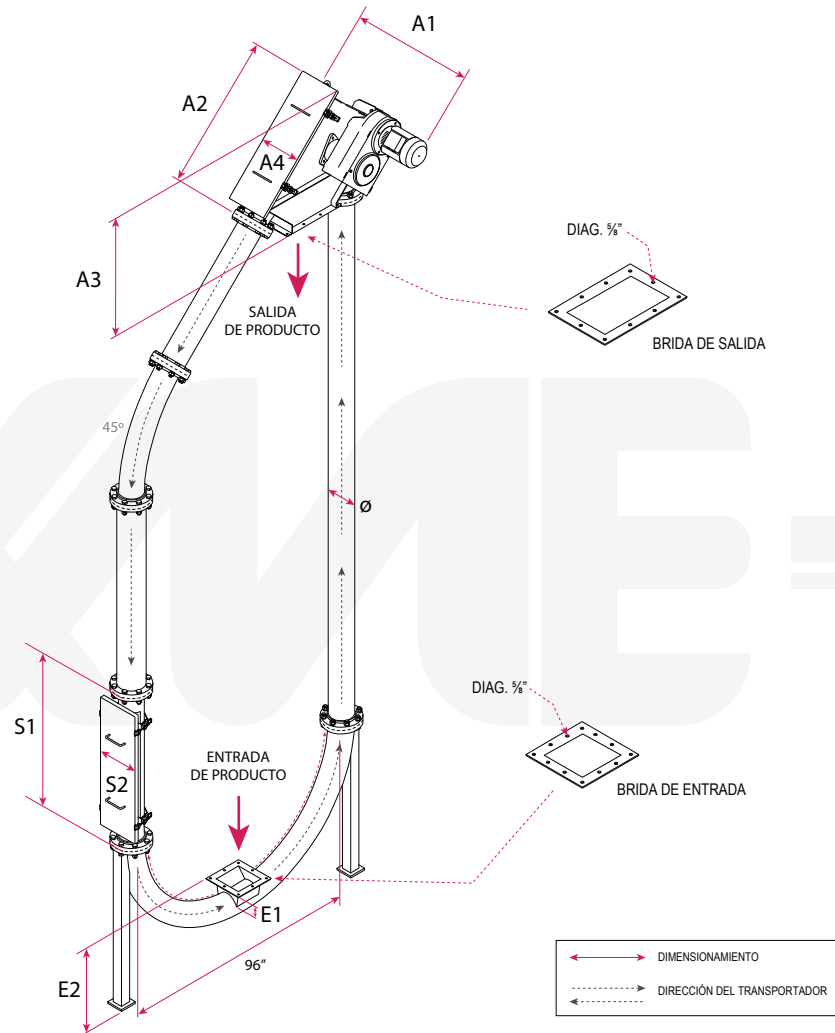

*La brida de entrada / salida del producto puede adaptarse a su sistema actual.

TRANSPORTADOR TUBULAR DE CADENA - TIPO VERTICAL

DIMENSIONES DE LA BRIDA DE SALIDA (PULGADAS)

TIPO	J1	J2	J3	J4	J5	J6	J7	J8
115	14 ¹⁵ / ₁₆	10 ¹ / ₄	11 ¹ / ₂	7 ¹ / ₈	4 ¹¹ / ₁₆	4 ⁵ / ₈	1/2	1/2
140	15 ¹ / ₂	11 ³ / ₈	11 ¹ / ₂	8 ⁵ / ₁₆	4 ³ / ₄	5 ⁷ / ₂₀	1/2	1/2
160	19 ⁷ / ₁₀	11 ¹ / ₂	15 ³ / ₄	7 ¹ / ₈	6	5 ³ / ₂₀	3/4	3/4
200	19 ⁷ / ₁₀	13 ³ / ₄	15 ³ / ₄	9 ¹ / ₈	5 ⁵ / ₈	5 ⁵ / ₈	1	1
270	28 ⁵ / ₁₆	18 ¹ / ₂	23 ³ / ₈	13 ³ / ₄	8 ⁷ / ₁₆	7 ¹ / ₄	1 ¹ / ₂	1 ¹ / ₂

BRIDA DE SALIDA

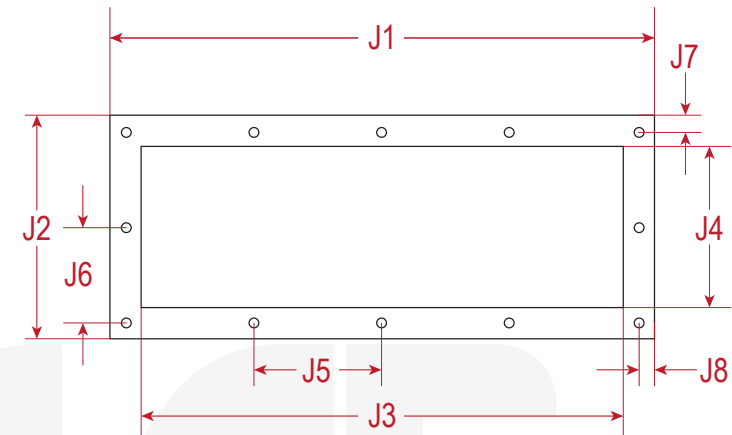

DIMENSIONES DE LA BRIDA DE ENTRADA (PULGADAS)

TIPO	I1	I2	I3	I4	I5	I6	I7	E1	E2
115	5 ⁵ / ₈	5 ⁵ / ₈	10	4 ¹ / ₄	4 ¹ / ₄	3/4	3/4	3 ⁷ / ₈	9 ⁵ / ₈
140	7	7	10	4 ¹ / ₄	4 ¹ / ₄	3/4	3/4	4 ⁷ / ₈	10 ⁵ / ₈
160	8	8	12	5 ¹ / ₄	5 ¹ / ₄	3/4	3/4	5 ⁵ / ₈	11 ⁵ / ₈
200	10	10	14	6 ¹ / ₄	6 ¹ / ₄	3/4	3/4	6 ⁷ / ₈	12 ⁵ / ₈
270	13 ³ / ₄	13 ³ / ₄	18	5 ¹ / ₂	5 ¹ / ₂	3/4	3/4	7 ⁵ / ₈	13 ⁵ / ₈

BRIDA DE ENTRADA

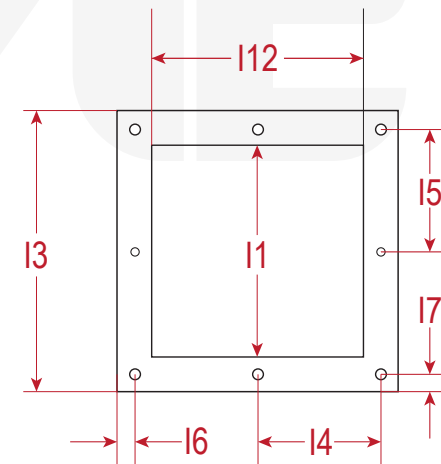

*La brida de entrada / salida del producto puede adaptarse a su sistema actual.